

RM65-E - Electric Driven Remote Monitor

- Electric driven slew and elevation
- Automatic grease lubrication optional
- 90° slew (maximum)
- 70° Elevation (as standard)
(45° above horizontal, 25° below horizontal)
- Electric 4-way Joystick controller supplied
- Unit pre-set to correct settings and tested prior to final packaging and dispatch
- 12v or 24v available
- Mounting flange with fasteners included
- Option of air or electric to turn water on/off
- Optional remote foam/fog nozzle available operated by air or electrics
- Optional Radio Frequency (R.F.) Control available
- 65mm (2½") ANSI 150lb flanged inlet connection
- Director nozzle supplied as standard - 28mm (1¼") orifice. 60 metres water throw at 7 bar
- Power requirements 24v 4amp - 12v 8amp

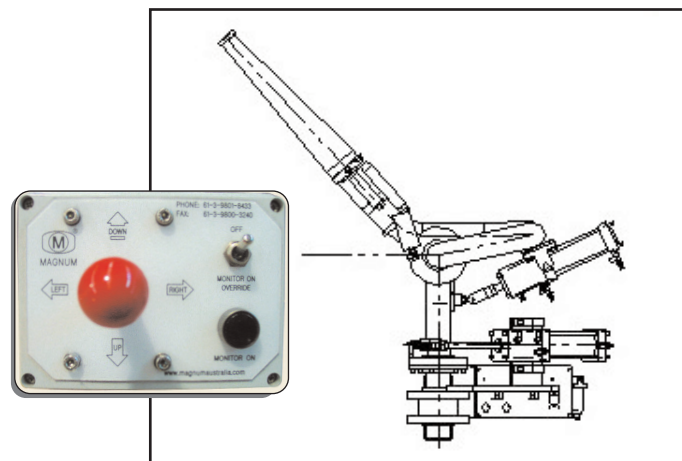
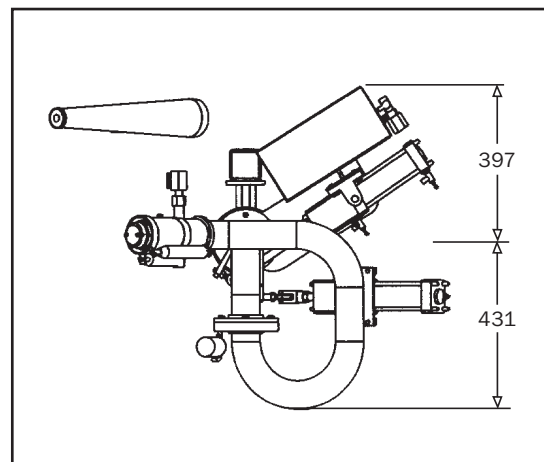
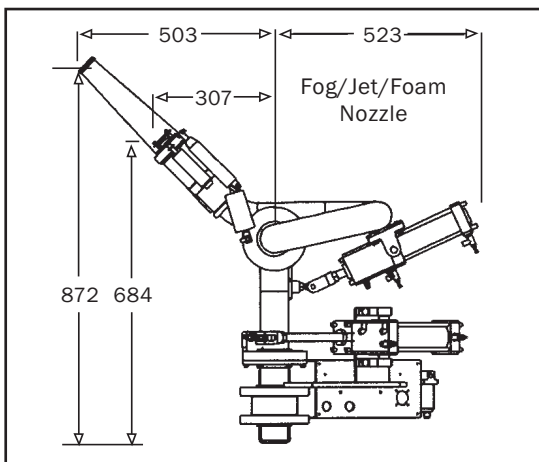
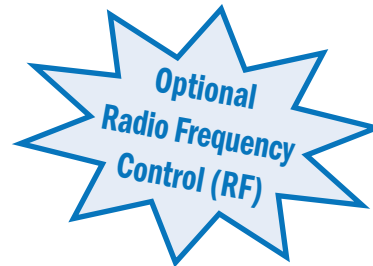

electric driven remote monitor
RM65-E