

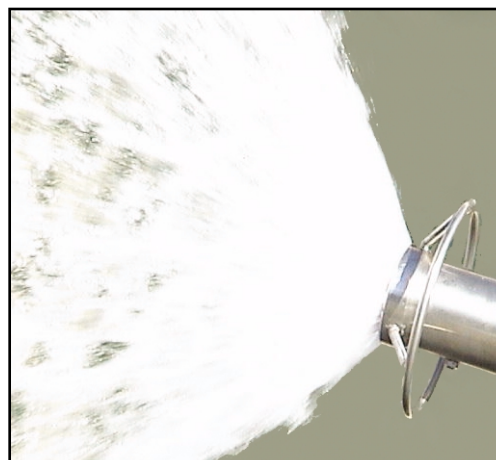

MAGNUM
Member of the Haviland Group of Companies

MM65 - Manual Monitor

- Easy installation
- Pressure tested to 3000 kpa
- 65mm (2 1/2") ANSI 150lb flanged inlet connection
- T Bar handle for controlled operation
- Engineered balanced and compact design - see dimensions
- Positive fixed positional swivel brake locking
- Designed for mobile or fixed mounted applications
- Patented "non-flog" Magnum Australia® swivel bearings
- Accepts Magnum 316 s/s fog nozzle for adjustable fan spray
- Director nozzle supplied -28mm (1 1/8") orifice as standard
- All s/s fasteners and locking components
- 12 month product warranty
- Spare parts readily available
- Fully serviceable

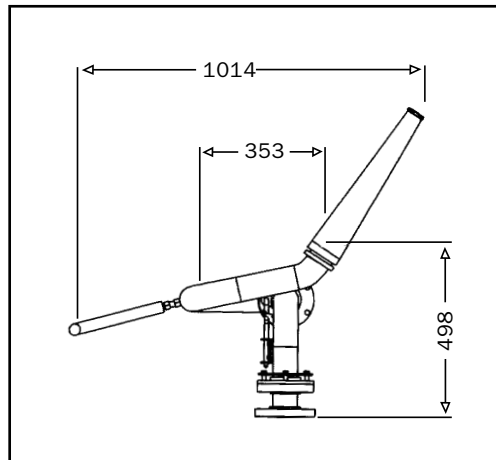
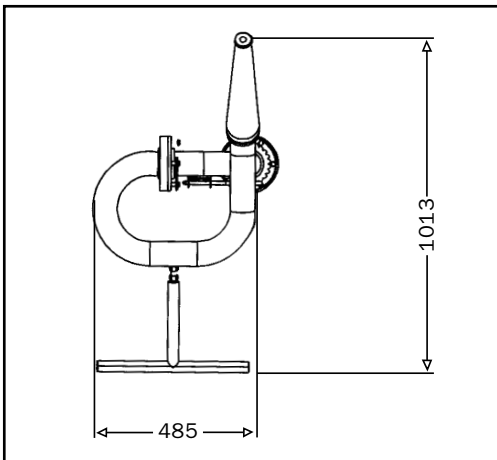

W
a
t
e
r
m
o
n
i
t
o
r

M
M
6
5