

QUALITY PRODUCTS

COOPER FLUID SYSTEMS OFFERS AN EXTENSIVE RANGE OF QUALITY PRODUCTS AND SYSTEMS FOR HYDRAULIC, LUBRICATION AND FLUID HANDLING APPLICATIONS

PR-Series, POW'R-RISER® Lifting Jack Safe, Efficient, Mobile Load Lifting

- 54, 90, 136 and 181 ton capacities with pneumatic or electric pumps for the toughest jobs
- 102mm ground clearance for transport over rail and rough terrain
- Three position handle provides easy tilt back and transport
- Complies with ASME/ANSI B30.1 specifications
- Easy to change external filter minimizes down time
- Rugged, fully enclosed 610 mm wide frame with no exposed fittings or hoses
- SUP-R-STACK™ Extension System allows lifting at all heights without blocking.

Features and Benefits Include:

- Rated Lifting Capacity: 54-181 tonne.
- Stroke: 356-686mm
- Maximum operating pressure: 700bar
- Standard 3.6m pendant cord for air driven units with pneumatic valves, and 6.1m pendant cord for electric driven units keeps operator away from the load.
- Versatility for rail maintenance. One jack for all cars from Internodal to High Hopper with 28 heights in between.



PRASA10027L
Pneumatic Air Pump Lifting Jack
90 ton (kN) Capacity



Machinery Maintenance

ENERPAC 

 **COOPER**
FLUID SYSTEMS

Ph 1300 026 673
for your nearest location

AUSTRALIA'S HYDRAULIC AND LUBRICATION SPECIALISTS
www.cooperfluidsystems.com.au A Division of Coventry Group Ltd ABN 37 008 670 102

PERTH OFFICE
Tel (08) 6272 5333
Fax (08) 6272 5350

ADELAIDE OFFICE
Tel (08) 8346 2705
Fax (08) 8346 7443

TOOWOOMBA OFFICE
Mobile 0417 930 591

MACKAY OFFICE
Tel (07) 4952 4844
Fax (07) 4952 4011

KALGOORLIE OFFICE
Tel (08) 9021 4000
Fax (08) 9021 3999

BRISBANE OFFICE
Tel (07) 3258 7222
Fax (07) 3258 7200

GLADSTONE OFFICE
Workshop 0400 203 400
Sales 0410 220 919

TOWNSVILLE OFFICE
Tel (07) 4774 3455
Fax (07) 4774 4902

ENERPAC 

LINCOLN

M

SMC

rts
RADICAL THROU SOLUTIONS

MUSTER
an Emerson brand

Wiggins
Power Systems

GRACO

macnaught

EATON

Aeroquip

SPECIFICATIONS

For power source, the following characters should be inserted in the 5th space of the model number.

Ordering Example:

Model No. PREME06014L is a 356 mm stroke, 54 ton model, with a manual valve and a 230VAC, 1ph, 50Hz electric motor.

- A Air Pump, 1416 l/min air consumption at 5.5 bar
- B 115VAC, 1ph, 50-60Hz, 20A
- E 208-240VAC, 1ph, 50-60Hz, Euro Plug, 10A
- I 208-240VAC, 1ph, 50-60Hz, USA Plug, 10A
- G ¹⁾ 208-240VAC, 3ph, 50-60Hz
- W ¹⁾ 380-415VAC, 3ph, 50-60Hz
- J ¹⁾ 440-480VAC, 3ph, 50-60Hz
- R ¹⁾ 575VAC, 3ph, 50-60Hz

¹⁾ Not available for 54 ton capacity.

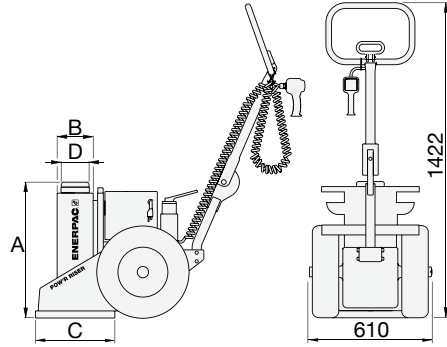

Capacity ton (kN)	Stroke (mm)	Electric Pump Model No. (230V - 1ph - 50Hz)	Weight (kg)	Air Pump Model No.	Weight (kg)	A (mm)	B (mm)	C (mm)	D (mm)	Max. Additional Stack Height Using Optional Extension	Valve Type
54 (533)	356	PREME06014L	177	PRAMA06014L	177	610	162	356	102	813*	Manual
	686	PREME06027L	272	PRAMA06027L	272	940	162	356	102	279	
90 (889)	406	PREME10016L	231	PRAMA10016L	231	660	178	457	102	533**	Manual
	686	PREME10027L	272	PRAMA10027L	272	940	178	457	102	279	
	406	-	-	PRASA10016L	231	660	178	457	102	533**	Pneumatic
	686	-	-	PRASA10027L	272	940	178	457	102	279	
136 (1333)	394	-	-	PRASA15016L	258	660	203	457	127	533**	Pneumatic
	673	-	-	PRASA15027L	321	940	203	457	127	279	
	394	PREME15016L	258	-	-	-	203	457	127	533**	Manual
	673	PREME15027L	321	-	-	-	203	457	127	279	
181 (1778)	394	-	-	PRASA20016L	290	660	241	457	152	533**	Pneumatic
	673	-	-	PRASA20027L	374	940	241	457	152	279	

* Based on one 457mm and one 279mm extension and one 76mm spacer.

** Based on one 457mm extension and one 76mm spacer.

Swivel Caps & Locking U-Rings

Cap. (kN)	Swivel Load Cap	Locking U-Rings					Set Model No.	Locking U-Ring Sets Include			
		25mm	76mm	114mm	140mm	254mm		Quantity & Model Nos.			
		2x	1x	2x	1x	2x		1x			
534	PRTS60	PRU11	PRU13	PRU14	-	PRU110	¹⁾ PRUS126	PRU11	PRU13	PRU14	-
							²⁾ PRUS137	PRU11	PRU13	PRU14	PRU110
890	PRTS60	PRU11	PRU13	PRU14	-	PRU110	¹⁾ PRUS126	PRU11	PRU13	PRU14	-
							¹⁾ PRUS137	PRU11	PRU13	PRU14	PRU110
1334	PRTS150	PRU151	PRU153	-	PRU155	PRU1510	²⁾ PRUS1526	PRU151	PRU153	PRU155	-
							³⁾ PRUS1537	PRU151	PRU1510	PRU155	-
							²⁾ PRUS2026	PRU201	PRU203	PRU205	-
1779	PRTS200	PRU201	PRU203	-	PRU205	PRU2010	³⁾ PRUS2037	PRU201	PRU2010	PRU205	-

¹⁾ For 356mm & 406mm stroke models / ²⁾ For 686mm stroke models / ³⁾ For 394mm stroke models



Locking Rings

SUP-R-STACK Extensions

Increase useful height from 127mm to 457mm.

Model No.	Size (mm)
PRE5	127
PRE7	178
PRE9	229
PRE11	279
PRE14	356
PRE18	457
Extension Set PRES6024	Includes PRE5, PRE7, PRE11 & PRE18

Spacers

Fine tune your extension stack height.

Model No.	Size (mm)
PRS1	25
PRS2	51
PRS3	76
Spacer Set PRS4	Includes (2) PRS1, (1) PRS2 & (1) PRS3

WARNING!

Extensions: Any two extensions may be stacked for loads up to 54ton. For loads over 54ton or strokes over 356mm only one extension & one spacer can be used.

Spacers: Never exceed 76 mm in total spacer height.

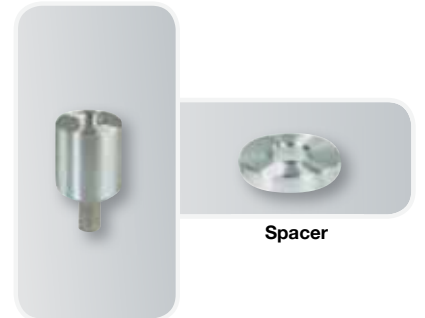

SUP-R-STACK™ Extension

Spacer